

Active computing experiment in modeling the dynamics of mechatronic systems

Yu. V. Shornikov^{1,2}, K.A. Timofeev^{1*}, and V.N. Petukhov³

¹Novosibirsk State Technical University, Novosibirsk State Technical University, Karl Marx avenue, 20, 630073 Novosibirsk, Russia

²Institute of Automation and Electrometry of the Siberian Branch of the Russian Academy of Sciences (IA&E SB RAS), Academician Koptyuga avenue, 1, 630090 Novosibirsk, Russia

³3V Services LLC, Trubnaya st. 25/1, 127051 Moscow, Russia

Abstract. In the process of debugging the structure of dynamic models of various technical systems, the need arises for direct intervention in the modeling process. The ability to control the modeling process in real time and, if necessary, change the values of phase variables or the structure of the model, is a flexible way to analyze the adequacy of the model using tool-oriented means. By changing the structure and parameters of the model during the modeling process, you can interactively analyze the influence of a particular parameter (block/macrostructure) on the behavior of a dynamic system. This method of carrying out calculations with the possibility of reconstructing the structure and parameters during the modeling process is called an active computational experiment. In the work, an active computational experiment is demonstrated using the example of a mechatronic system - drive using simulation software ISMA (Novosibirsk, NSTU NETI) and SimInTech (Moscow, MSTU / 3V-Service LLC).

1 Introduction

The process of debugging complex dynamics models involves repeated changes in system parameters. The user should be able to make adjustments to the developed model directly during the modeling process. This approach is called an active computational experiment. Modern tools for modeling system dynamics, such as SimInTech [1], ISMA [2], MVS [3] support this technology for a class of mathematical models

$$\mathbf{y}' = \mathbf{f}(t, \mathbf{y}) \quad \mathbf{y}(t_0) = \mathbf{y}_0 \quad (1)$$

where $\mathbf{y} \in R^N$ is the state vector; $\mathbf{f}: R \times R^N \rightarrow R^N$ – nonlinear vector function satisfying the Lipschitz condition; $\mathbf{y}_0 \in R^N$ – vector of initial conditions.

The active experiment mode allows variations in model parameters and modification of the original structure. Changing the value of element properties does not require stopping the modeling process. Modifying the structure allows you to change the structure by adding new

* Corresponding author: k.timofeev@corp.nstu.ru

elements, deleting old ones, and changing connections between elements. Also in this mode you can change properties that are not available in the parameter variation mode, for example, change the type of functional dependence in a nonlinear block.

When the modeling process is interrupted at a point in time, T_1 the program remembers the simulation results, and when restarted, calculations begin from the moment $T_1 + h$, where h is the integration step. In this case, the values of the phase variables at the moment of time are chosen as the initial conditions T_1 .

Let us consider the operation of an active experiment using the example of a continuous model of a drive with a DC motor [4]. Software models from class (1) were developed in ISMA and SimInTech and are shown in Figure 1 and Figure 2. When describing a model in ISMA and SimInTech, there is no fundamental difference between block diagrams. Some differences are due to the functionality of individual blocks.

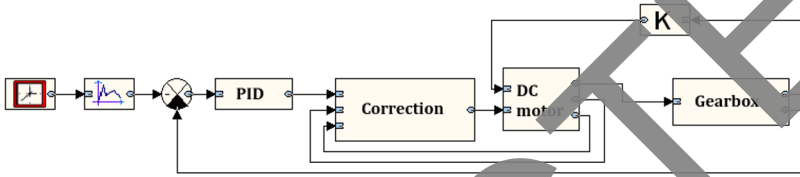

Fig. 1. Block diagram of the continuous drive model in ISMA

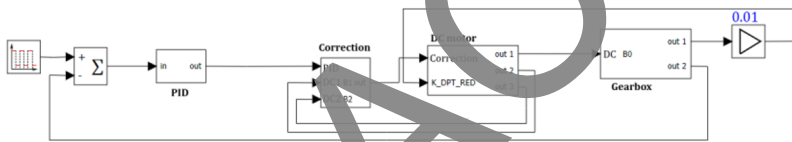

Fig. 2. Block diagram of a continuous drive model in SimInTech

The PID model is shown in Figure 3.

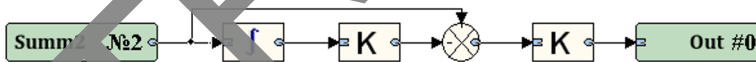

Fig. 3. PID model

The «Correction» model is shown in Figure 4.

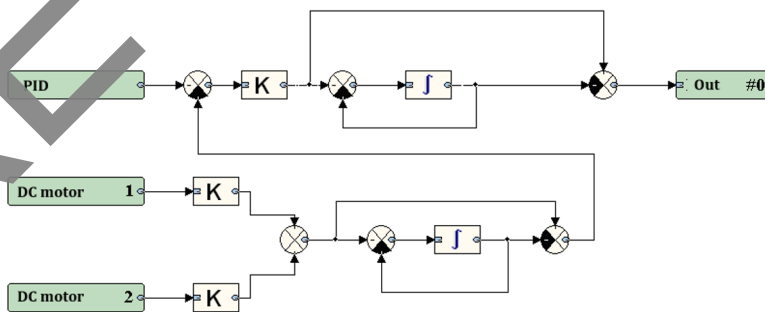

Fig. 4. «Correction» model

The «DC motor» model is shown in Figure 5.

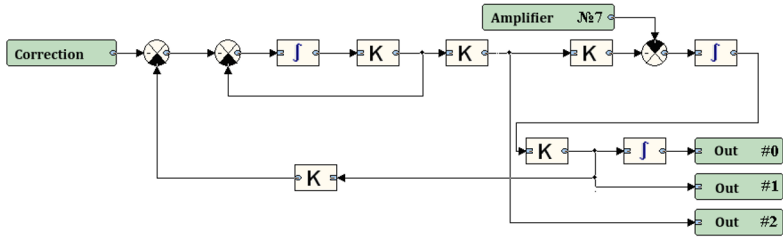

Fig. 5. «DC motor» model

The «Gearbox» model is shown in Figure 6.

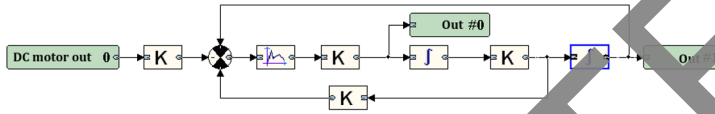

Fig.6. «Gearbox» model

The system uses two nonlinear blocks. The first block «Square pulse» determines the shape of the input signal. The signal at the output of the element has the form (Figure 7, nonlinearity editor in ISMA)

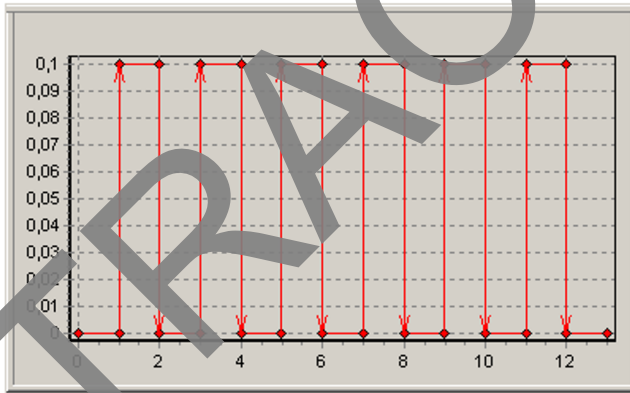

Fig.7. Form of the input signal of the «Square pulse» block

The second block sets the dead zone $[-0.002, 0.002]$ (backlash) in the gearbox circuit (Figure 8). The presence of a dead zone makes this problem nonlinear and stiff.

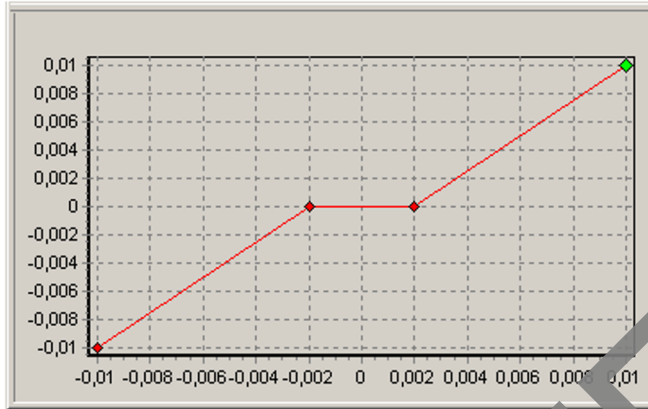

Fig. 8. Nonlinear gearbox link in the ISMA structural editor

2 Numerical experiment

The transmission coefficient of the original model (Fig. 1) varied from $k=0.01$ to $k=1$. The results of the interactive experiment ASTKEY (asynchronous key) in ISMA are shown in Figure 9. The results in SimInTech are shown in Figure 10. At the moment of $t \approx 6$ pressing any key on the keyboard, the process is paused and the coefficient is changed to $k = 1$. From this moment, the system moves unstably with a new coefficient until the moment in time $t \approx 8$ when a new “stop” is executed and the coefficient is assigned the original value $k = 0.01$. And from this moment on, a steady transition process continues.

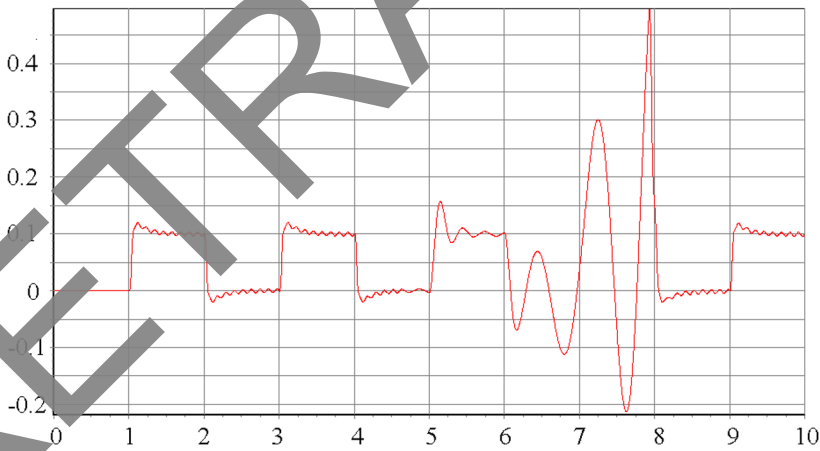

Fig. 9. The result of an active experiment at ISMA

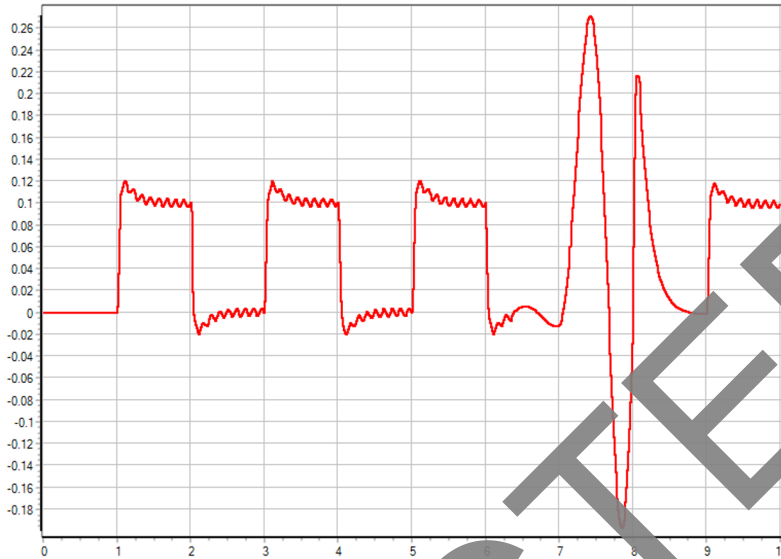

Fig. 10. The result of an active experiment in SimInTech

3 Conclusion

As can be seen from the obtained graphs, the results of computational experiments in ISMA and SimInTech are qualitatively the same. At the same time, it is necessary to note one drawback of the technology of manual intervention in the computing process: the irreproducibility of the results of the operator's actions. This determines the permissible numerical difference in the results obtained. That is, in order to reproduce the result of an active computational experiment again, it is necessary in the original model to provide for the possibility of logging changeable model parameters to a file. The SimInTech software package provides the «To File» block for this purpose, or you can use the built-in «Event Recorder» tool.

It should be noted that not all traditional integration schemes, for example, Euler, Runge-Kutty- Fehlberg RKF78 and some implicit ones, turn out to be numerically stable. This is due, firstly, to discontinuities of the first kind in the nonlinear input signal (Figure 7) and the stiffness that appears as a result of the organization of the «backlash» mode (Figure 8). In this regard, in this computational experiment, ISMA used the original explicit DISPF method of variable order and step with stability control [2], and SimInTech also used the original ARK21 (Adaptive 1) method [5].

The possibility of interactively changing the structure of the model (1) and parameters during an active computational experiment requires re-sorting the model and a new interpretation. In SimInTech, this mode is implemented by stopping the task, remembering the restart point and then starting from this point. It should be noted that not with every change in structure a shock-free restart can be guaranteed. In ISMA and SimInTech, parametric reconstruction of a model can be performed without reinterpretation. It should also be added that many modern modeling systems (domestic - MVS, Anydynamic [6], foreign - MATLAB\ Simulink [7], OpenModelica [8], AmeSim [9] and others) have built-in means of varying parameters, but some of them prohibit interactive modification of the original model and parameters during a numerical experiment.

In conclusion, we note that domestic modeling and simulation tools are in no way inferior to advanced modern foreign analogues, and in some cases are ahead of the latter. It should be

noted that the considered domestic tools have found wide application not only in industrial research, but also in education and science. For many years, ISMA, SimInTech, MVS have been studied by students and graduate students of NSTU, MSTU, SPbSPU and other Russian universities and are used to study complex dynamic processes in various spheres of human activity.

References

1. D. I. Smagin, K. I. Starostin, R. S. Saveliev, A. A. Satin, A. A. Pritulkin, T. D. Makovskaya, Modeling of failures of the electricity system (SES) ac longhaul passenger plane in the software package SimInTech, *Comp. nanotechnol.*, **2**, 63–70 (2019)
2. E. Popov, Y. Shornikov, Features of Heterogeneous Dynamic Systems, *International Conference Engineering and Telecommunication (En&T)*, 1–6 (2020)
3. Yu. B. Kolesov, Yu. B. Senichenkov, A. Urquia, C. Martín Villalba, Hybrid Systems. Preliminary Comparative Analysis of Modelica and Model Vision Language, *University Scientific Journal*, **8**, 102-111 (2014)
4. V.V. Bushuev, Modeling of control loops of the servo feed drive, *STIN*, **3**, 7-14 (2016)
5. L. M. Skvortsov, Construction and analysis of explicit adaptive onestep methods for solving stiff problems, *Computational Mathematics and Mathematical Physics*, **60(7)**, 1078–1091 (2020)
6. B. I. Klebanov, Application of the dynamics package for the development of simulation models of social systems. *Modern science-intensive technologies*, **4**, 46-51 (2022) DOI 10.17513/snt.39106.
7. M. V. Sidorov, M. A. Karpov, M. N. Kholmullin, *Vehicle transmission modeling via Simulink software*, *AMF Conference Proceedings : 2*, Krasnoyarsk, 29–31 July 2021, Krasnoyarsk, 030017 (2022) DOI 10.1063/5.0093779.
8. A. Urquía, Moraleda and C. Martín Villalba, *Modeling and simulation in engineering using Modelica* (Madrid, Spain: UNED Editorial, 2018)
9. Wei Zhou, Simulation of Hydraulic System Faults for Marine Machinery Based on AMESim, *Journal of Coastal Research*, **94(sp1)**, 357-361 (2019)